



Conclusive summary on EEG activities

R. Bonifetto

February 12, 2020

Summary

- Training
- Acting
 - Experimental activities
 - AC losses in DEMO magnets
 - Mechanics → contribution to SRT qualification
- Taking away...

EEG training program

Training on conductor and superconducting magnet manufacturing processes of LTS and on mechanical analyses

- **SPC** → active participation to on-going activities/tests of samples (Jul.2016)
- **ENEA/ICAS/TratosCavi/Criotec/ASG** → participation to on-going activities on conductor, WP and magnet manufacturing (Spring 2017, Jun.2019)
- **University of Tor Vergata** → training and participation to the on-going activities on the mechanical analyses of DEMO TF magnets (Nov.2016)
- **Forschungszentrum Jülich** → training on the macro tool for coarse mechanical dimensioning of the coils (Jan.2017)



Experimental activity: sample design / test

- Thermal-hydraulic characterization of the conductor
 → instrumented sample tested in SULTAN (2016)

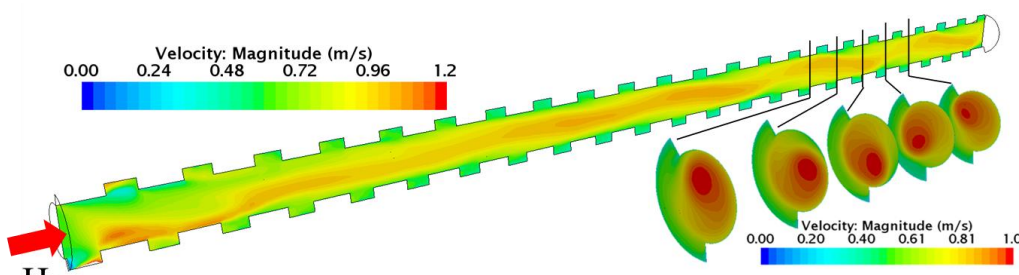
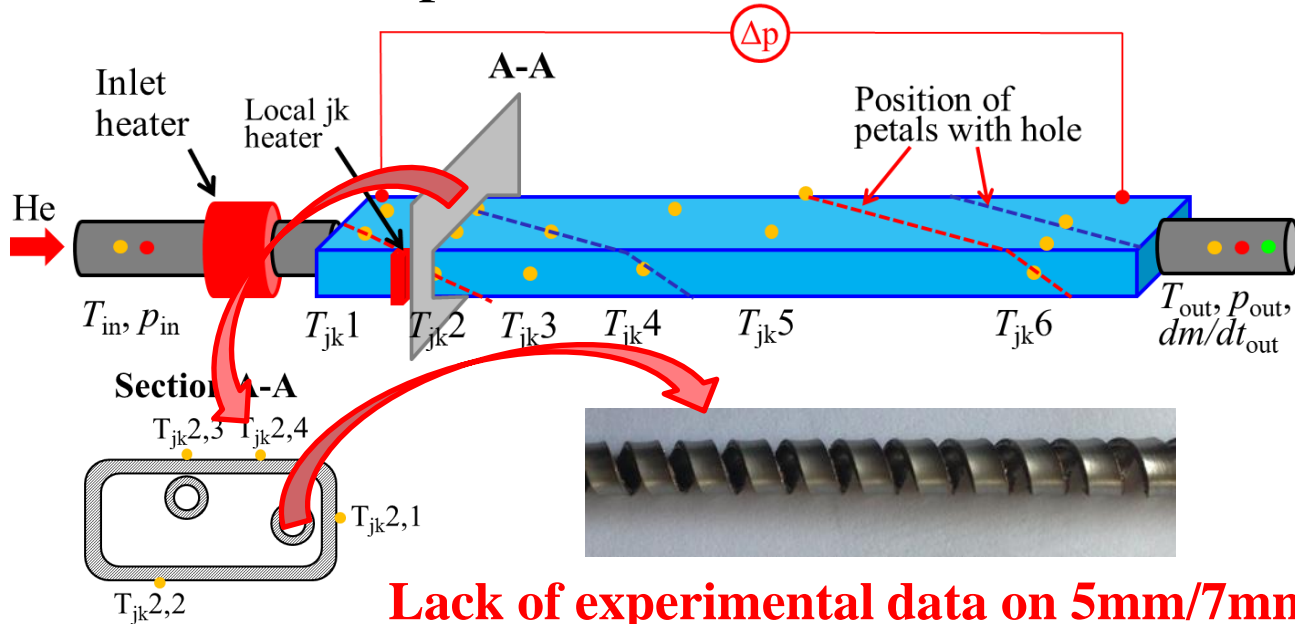

CFD analyses

BUT:

need for **tools qualification!**

→ experimental data

Experimental activity small facility design

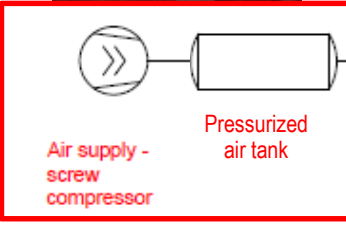

p sensors with equalization chamber

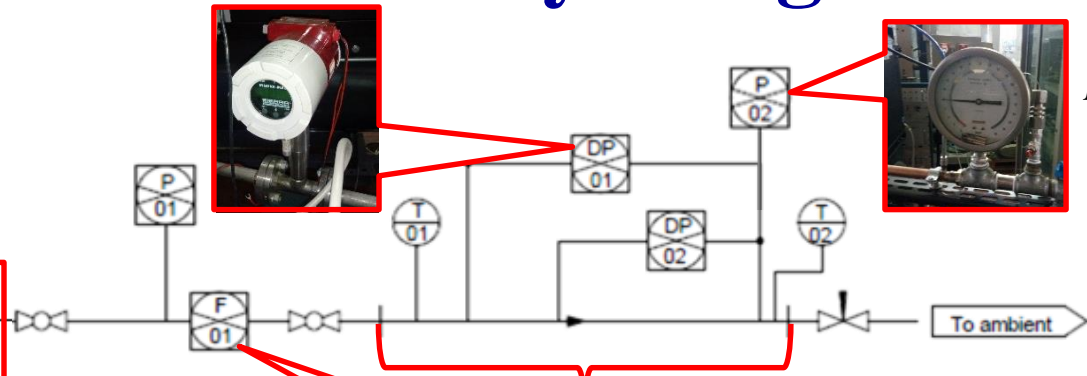

Flow meter (e.g. thermal mass flow meter)



Test section

Several Δp measurements on different lengths (redundancy)

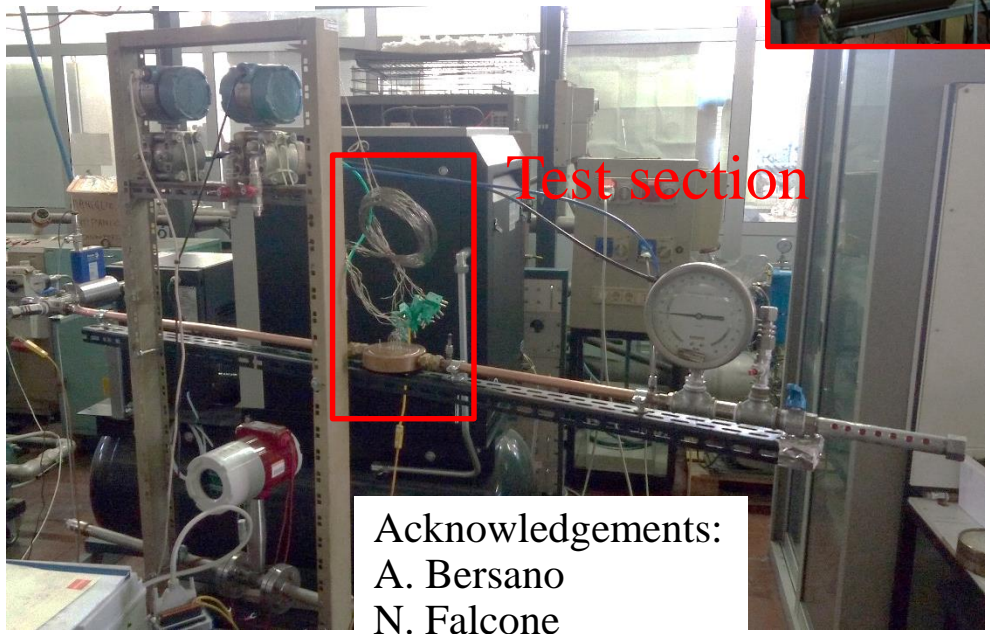

Test section

Open issues:

- Odd pressure drop measurements in some recent tests



Acknowledgements:
A. Bersano
N. Falcone

Analyses: AC losses in DEMO magnets

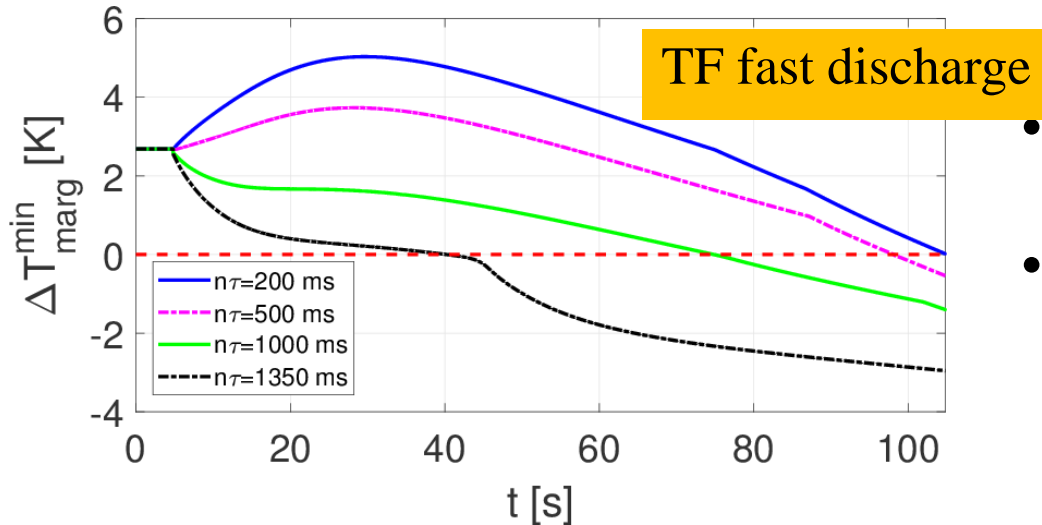

- $n\tau \leq 500$ ms $\rightarrow \Delta T_{\text{marg}} < 0$ when $I \sim$ few kA
- Otherwise: possible quench initiation

CS and PF operation

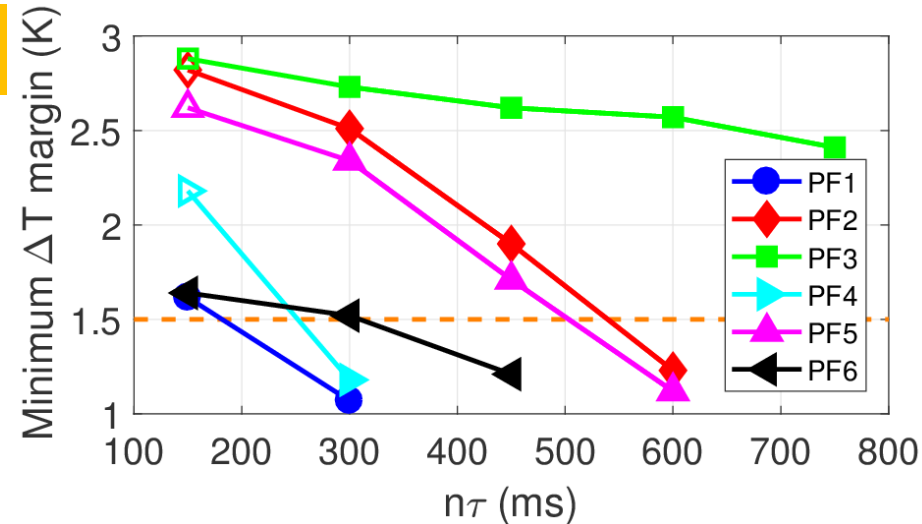
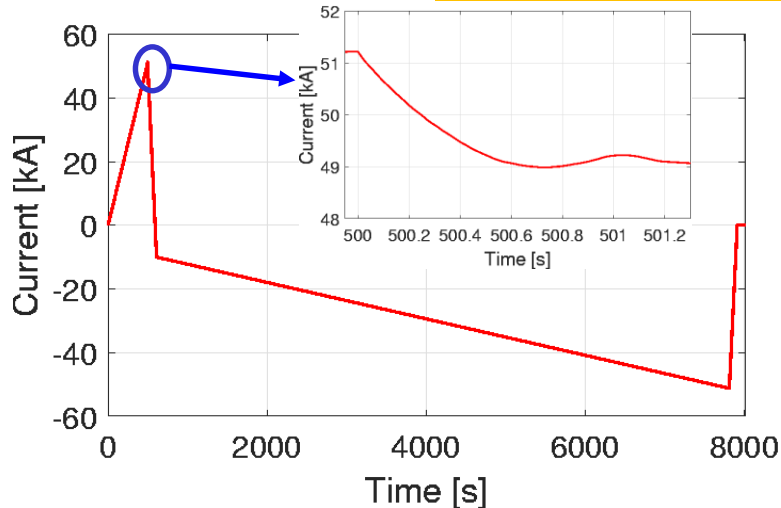

- PF 1, 4 and 6: $n\tau \leq 150$ ms
- PF 2 and 5: $n\tau \leq 450$ ms

Support to mechanical analysis: SRT

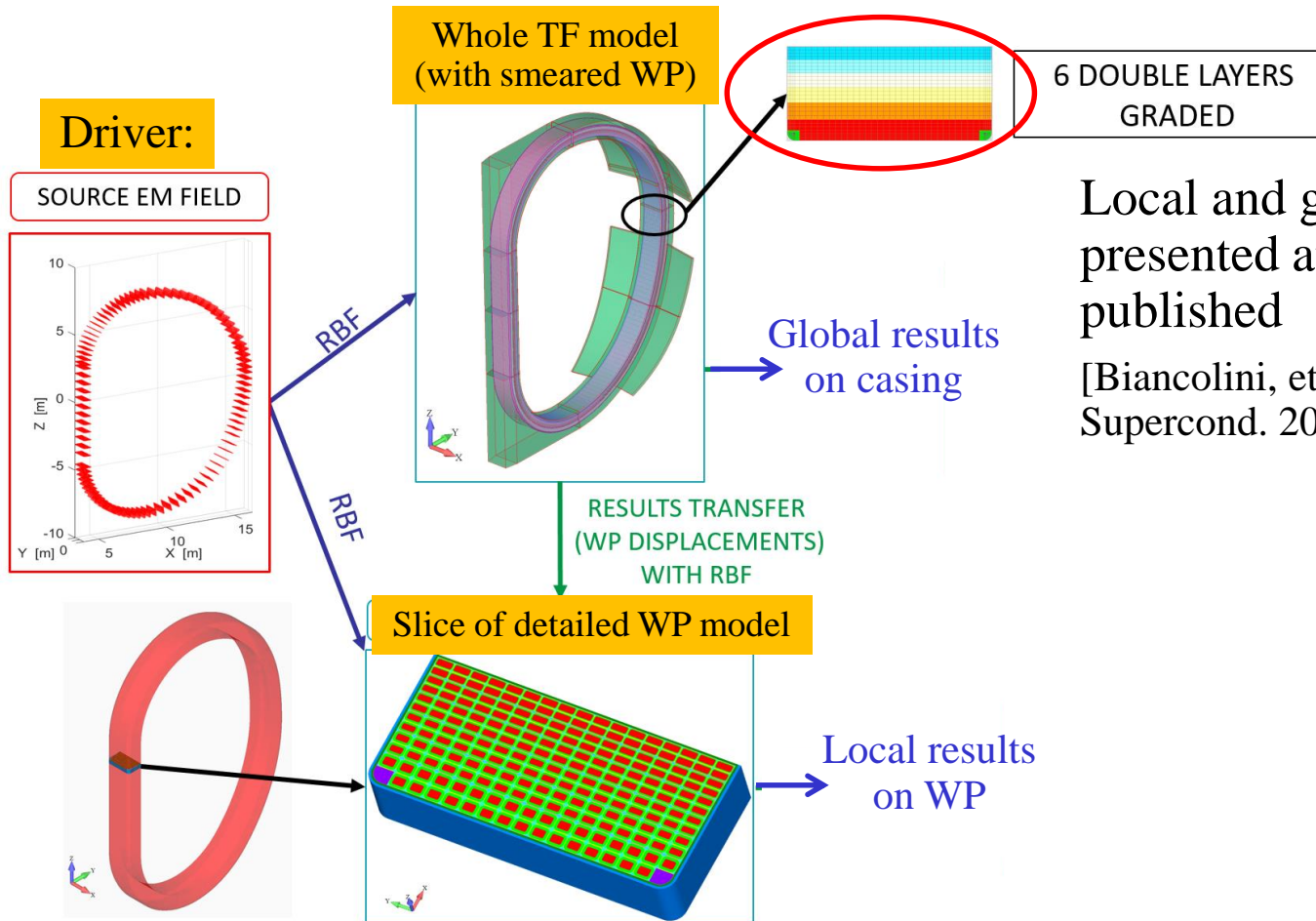

Stress-recovery tool (SRT) is being applied at UTV to DEMO TF ENEA design



Local and global SRT results presented at EUCAS 2017 and published

[Biancolini, et al., IEEE Trans. Appl. Supercond. 2018]

Taking away...

- Basis of mechanics of SC magnets
- Hands-on experience on samples/instrumentation/tests 
- Small facility at PoliTo for pressure drop measurements (*as soon as we will be sure it works* 😊)
- Ongoing collaboration with UniTus (F. Giorgetti) for coupled thermo-mechanical analyses 
- Visits to several institutions / laboratories

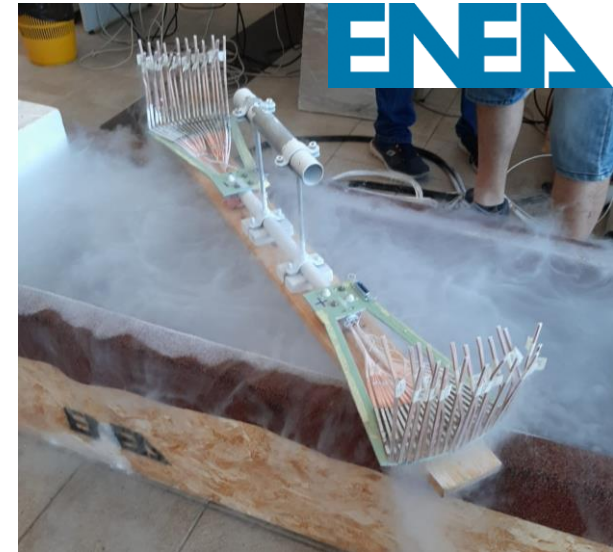

Thank you for your attention!